

TECHNICAL DATA

TANDEM ROLLERS

BW 120 SL-5

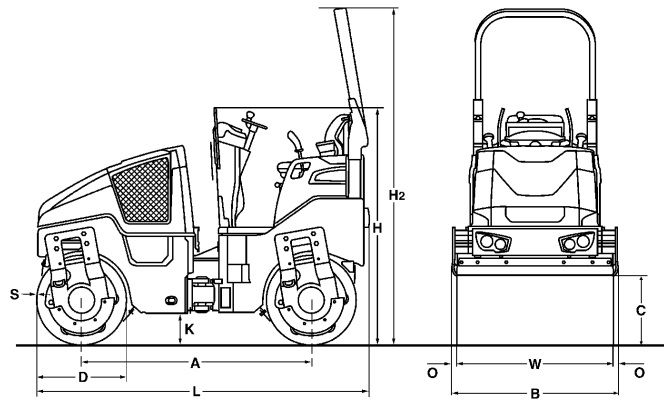



Dimensions in inch

	A	B	C	D	H	H2	K	L	O	S	W
BW 120 SL-5	69.0	50.1	20.6	27.6	71.2	101.1	10.0	99.6	1.4	0.39	47.2

Shipping dimensions in cub.yd

BW 120 SL-5

without ROPS

7,614

with ROPS

10,811

Machine type	Compaction output (cub.yd/h) at recommended soil layer thicknesses		
	Gravel, sand	Mixed soil	Silt, clay
BW 120 SL-5	111.2-222.4	85.0-163.5	56.2-111.2

Machine type	Compaction output (t/h) at different asphalt layer thicknesses		
	0.8-1.6 in	2.4-3.1 in	3.9-4.7 in
BW 120 SL-5	26.2-58.9	52.3-91.6	91.6-157.0

Technical Data**BOMAG
BW 120 SL-5****Weights**

Operating weight w. ROPS CECE	lb	5,622
Average static linear load CECE	lb/in	59.4
Grossweight	lb	6,504

Dimensions

Working width	in	47.2
Track radius, inner	in	96.5

Driving Characteristics

Speed	mph	0- 5.6
Working speed with vibration	mph	0- 3.1
Max. gradeability without/with vibr.	%	40/30

Drive

Engine manufacturer		Deutz
Type		D 2.2
Emission stage		Stage V / TIER4f
Cooling		water
Number of cylinders		3
Performance ISO 14396	hp	24.7
Performance SAE J 1995	hp	25.0
Speed	rpm	2.300
Electric equipment	V	12
Driven drum		front + rear

Brakes

Service brake		hydrost.
Parking brake		hydromec.

Steering

Steering system		oscil.artic.
Steering method		hydrost.
Steering / oscillating angle +/-	deg	32/10.0
Crab walk	in	0- 2.0

Exciter system

Vibrating drum		front + rear
Drive system		hydrost.
Frequency	vpm	72
Amplitude	in	0.020
Centrifugal force	lb	8,992/2,023

Sprinkler System

Type of sprinkling		pressure
--------------------------	--	----------

Capacities

Fuel	gal	9.2
Water	gal	43.6

Technical modifications reserved. Machines may be shown with options.

Standard Equipment

- Hydrostatic travel and vibration drive
- Travel drive in series
- 2 scrapers per drum, spring loaded and tiltable
- Pressure sprinkler system with interval switch
- Multi function travel lever
- Multi-function display incl. operating hour meter
- Water level
- Emergency STOP
- Individual control, vibration
- Intelligent Vibration Control (IVC)
- Integrated storage compartment
- Adjustable operator's seat
- Seat contact switch
- Vandalism protection
- 12V socket
- Working lights front and rear
- Back-up alarm
- Lashing eyes, galvanized
- Single point lifting device
- Lockable engine hood made of composite material

Optional Equipment

- Foldable ROPS incl. seat belt
- Sun roof, foldable with ROPS
- Sliding seat incl. double travel lever
- ECONOMIZER with asphalt temperature display
- BOMAG TELEMATIC
- Indicator and hazard lights
- Rotary beacon
- Battery disconnect switch
- Theft protection
- Pointer
- Special painting
- ECOSTOP
- Anti-frost intake
- Tablet holder set
- JOBLINK measuring technology interface
- JOBLINK Bluetooth adapter
- BOMAP GPS antenna holder

